

- 3/4" NPT
- Nylon Body
- 2-Way
- Piloted Diaphragm
- Normally Open



Materials	Seals:	NSF Approved EPDM
	Orifice:	Pilot Main
Electrical	Housing:	NEMA 4/4X Encapsulated - 1/2" Conduit
	Optional Housings:	DIN
	Standard Voltages:	24, 120, 240, AC, 60 and/or 50 Hz. Available 6, 12, 24 DC Contact GC Valves Customer Svc. For Additional Voltages
	Voltage Tolerance:	± 10% of applicable voltage
	Coil Classes:	F, H, N
	Standard Lead Length:	24 inches
Operating Temperature	Ambient (Nominal):	32° F to 125° F
Mounting	Position:	Any
Approvals*	Agency:	NSF/ANSI - 61-G / NSF-372 / UR Recognized

* Not available for all variations

Dimensions/Weight

Weight (oz.)

15.7

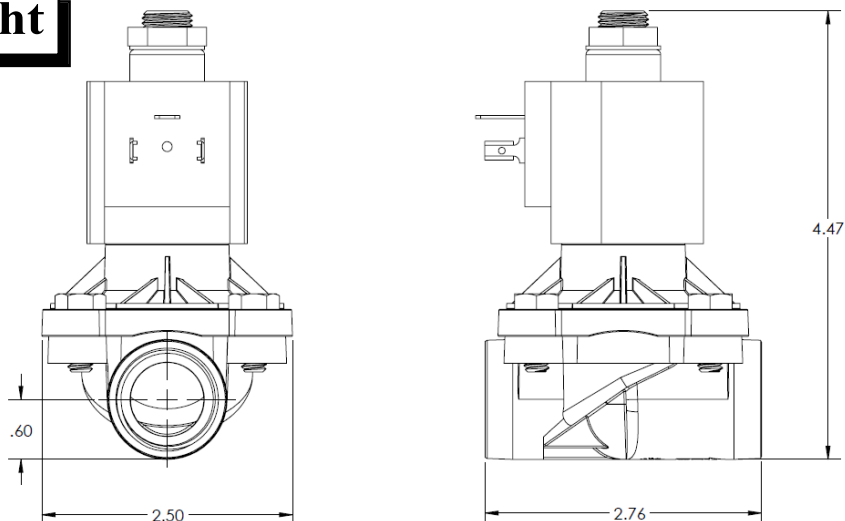



NS212 – 3/4" NPT, Nylon Body, Normally Open

Valve Selection List

Normally Open

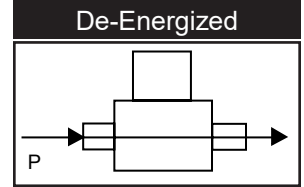
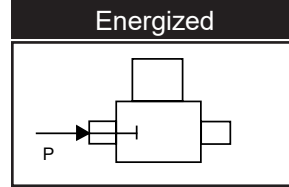
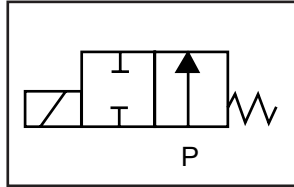

Pipe Size NPT	Orifice Size IN	C _v	Minimum	Operating Pressure Differential (psi)				Max Fluid Temp. °F	Seal Material	Power Consumption (Watts)		Model Code (120V/60HZ — 110V/50HZ Shown)
				Maximum						AC	DC	
				Air/Gas		Water						
				AC	DC	AC	DC			AC	DC	Nylon Body
3/4	3/4	6.7	3	-	-	150	140	180	EPDM	9	9	NS212GF02CPEG9

Part Numbering

1	2	3	4	5	6	7	8	9	10	11	12	13	14
N	S	2	1	2	G	F	0	2	C	P	E	G	9
Series				Operating Mode	Housing*	Coil Class*	Voltage*		Seal Material	Body Material	Pipe Connection	Orifice Size	
NS21				2: Normally Open	G: Conduit	F: Class F	02: 120/60 110/50		C: EPDM	P: Nylon	E: 3/4" NPT	G5:3/4"	
* See the "Engineering Guide" for additional voltages, variations and options.													

Coil Data

Coil Family	
Type	Size
ALL	S4

Frequency (Hz)	60	50	
Nominal Power (VA)	Inrush	46	46
	Holding	22	25

GC Valves Customer Service: 800-828-0484 (7:30 am to 5:00 pm ET)